

Standard Linear tables

Specials series

Just as for manufacturing on third parties' account, Meccanica Besnatese offers prototyping also in this field

The linear tables by single or multi-axis movement are manufactured according to the customer's needs starting from the draft of a specific project, the choice of the most suitable materials up to real machining as well as final inspection and the company's certification attached thereto.

The product is customised according to specific technical requirements as a result of the cooperation and confrontation between the company and the customer.

Meccanica Besnatese offers prototyping assistance also in this field. The linear tables by single or multi-axis movement are manufactured according to the customer's needs starting from the draft of a specific project, the choice of the most suitable materials up to real machining as well as final inspection and the company's certification attached thereto.

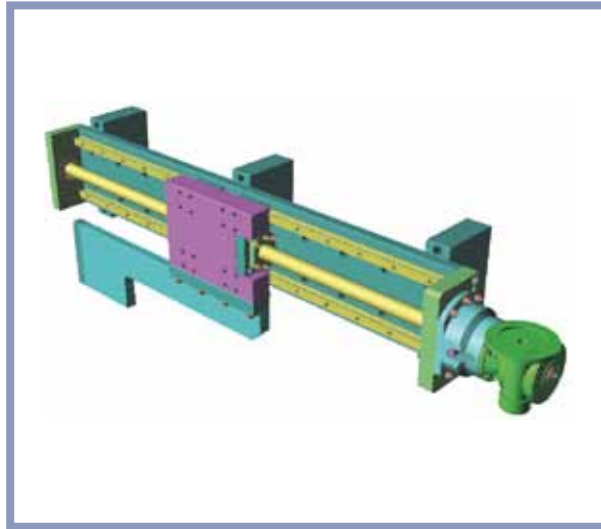

Coil extractor

Follow-up link of the rubber processing machine.
Control through screw and ratio-motor. Travel 600 m

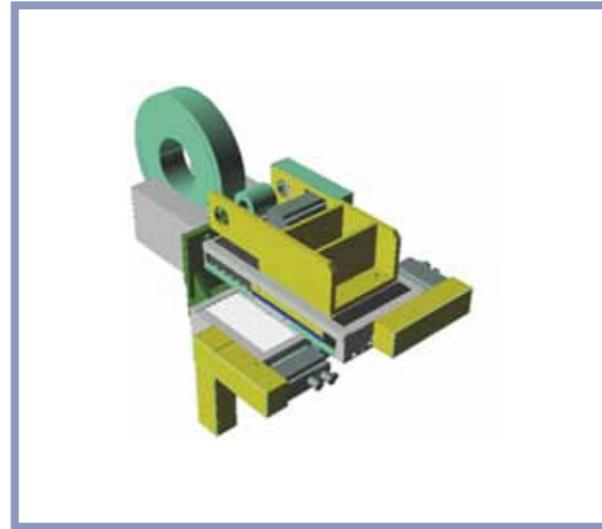

TV4 XY

CNC profile grinding machine with integrated electrospindle for thread grinding machine. Travel 150 x 150 mm.

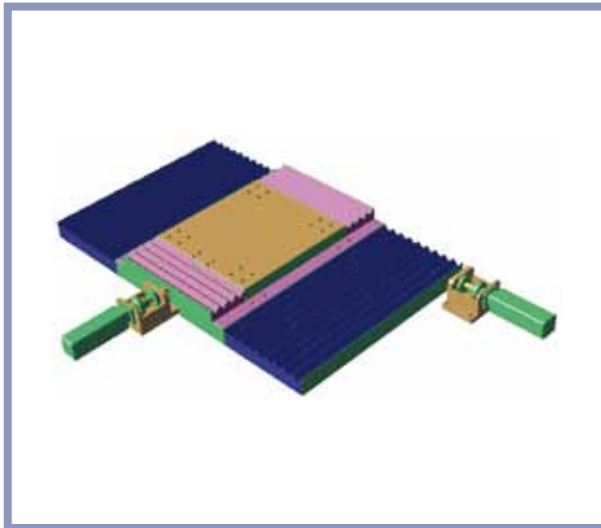

Prototype

Faceplate for laser cutting processing.
Travel 600x400 mm



TV3 + TV2

Micromilling of composite materials for the aerospace industry.
Travel 100 x 150 mm

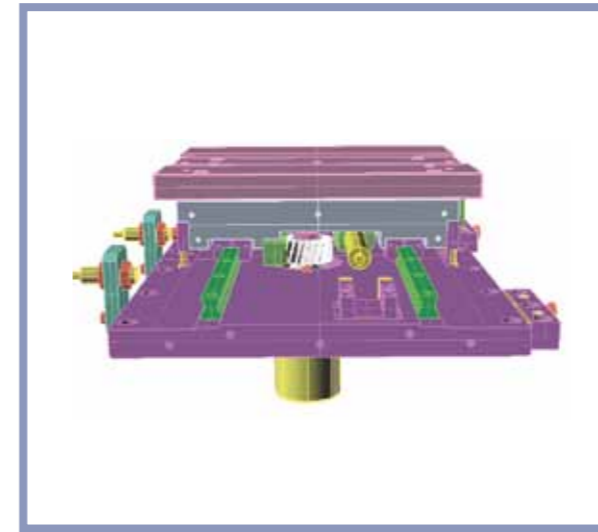

Hydraulic control slide

Piece positioning on the transfert line. Control with rotary hydraulic actuator.
Travel 250 mm

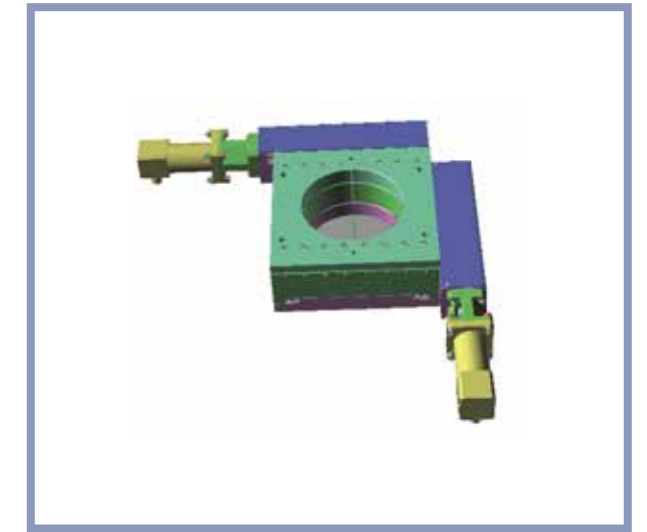

XY 210

Positioning of the optical device for the metallurgical laboratory.
Travel 150x150 mm

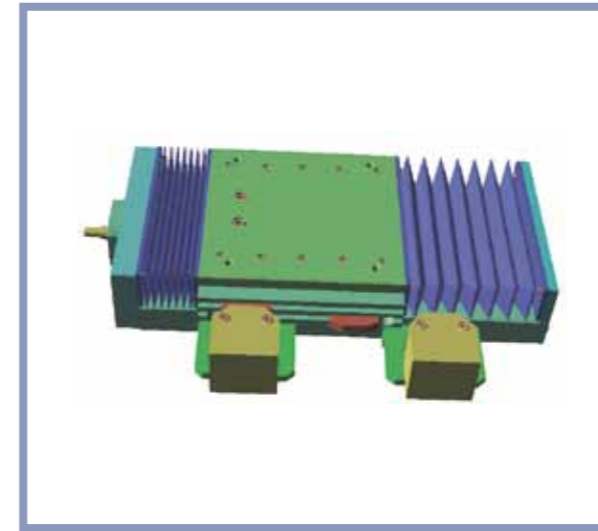
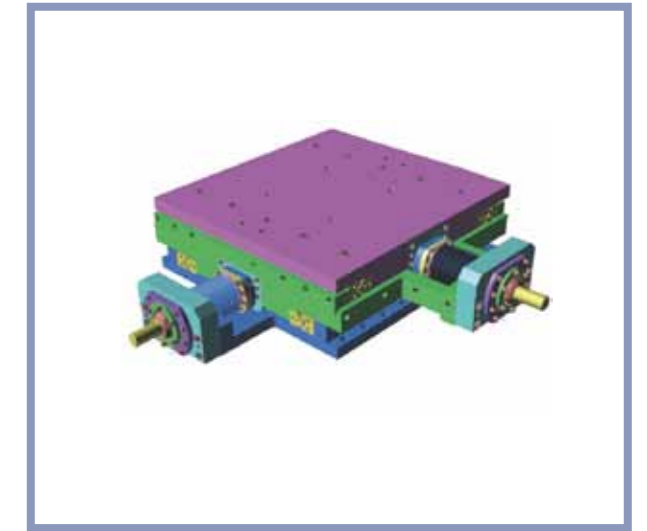

Table TV1

Electrospindle support for special machines cutting aluminium sections.
Travel 150 mm



XY 500

Coordinate unit bearing the pieces for the stainless steel welder.
Travel 200 x 200 mm.



Certified according to
EN 9100:2018, AS9100D, JISQ 9100:2016
ISO 9001:2015



MB
MECCANICA BESNATESE

Meccanica Besnatese s.r.l.

P. Iva 00184580124

info@meccanicabesnatese.com - Via Alfredo Di Dio, 47 - 21010 Besnate (VA) - Italy
Tel. +39 0331 274078 - Fax +39 0331 272328 - www.meccanicabesnatese.com